

Andrew

Design by Co.Studio

rvb[®]
Innovation since 1935

8029.--.58

Passe flexible simple

Slangdoorvoer

Ring for flexible



FR Instructions de montage et titre de garantie

NL Montagevoorschrift en garantiebewijs

GB Note of assembly and guarantee voucher

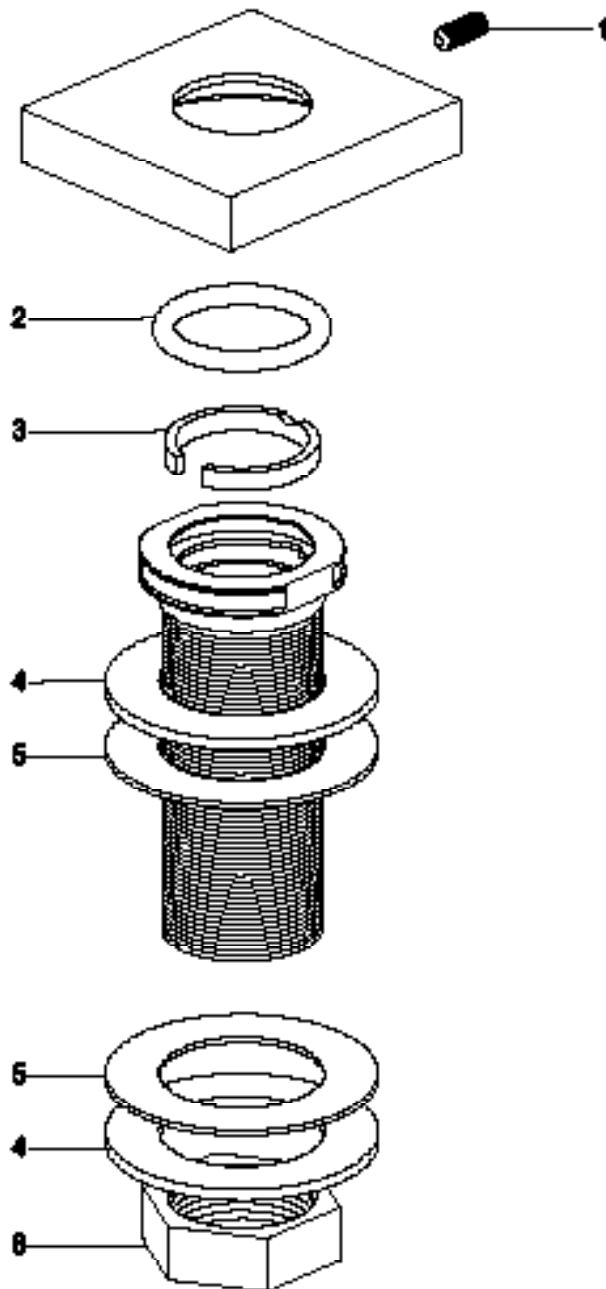

Picture



Technical drawing

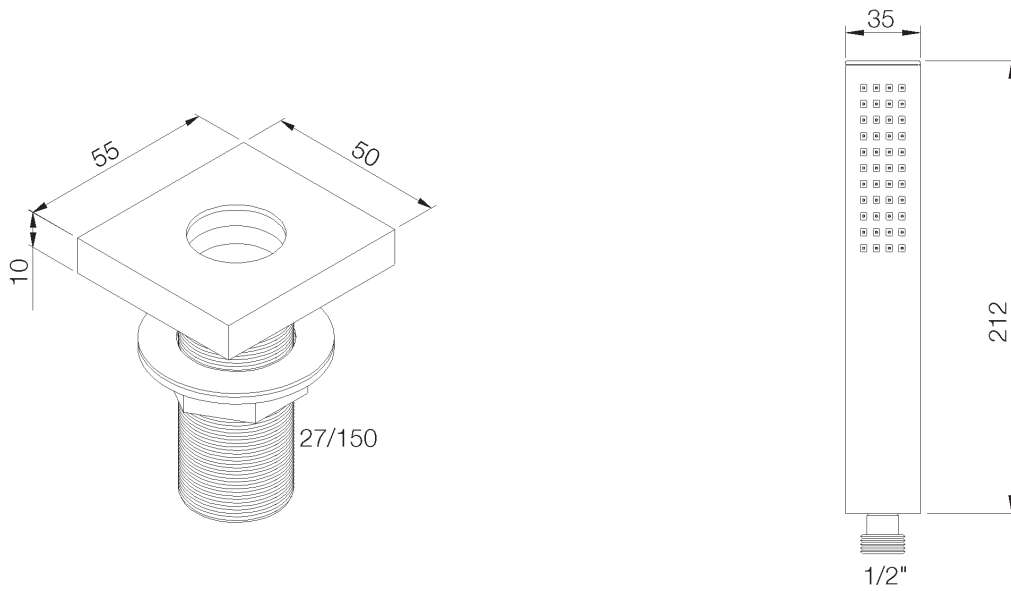

Matériel fourni
Geleverd materiaal
Included material

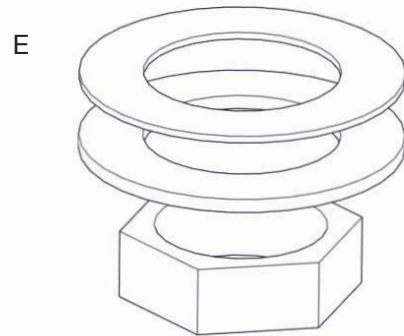
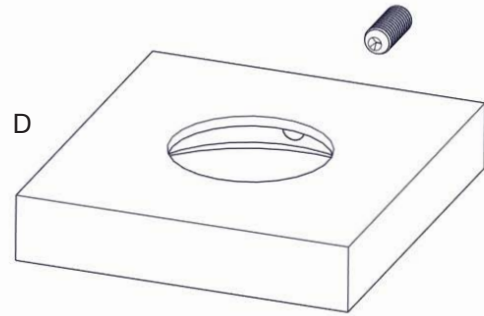
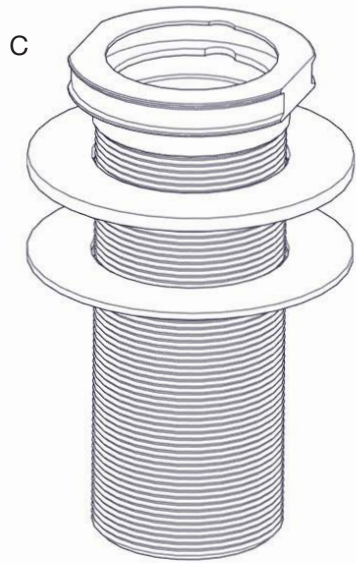
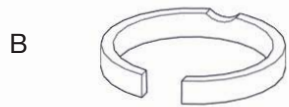

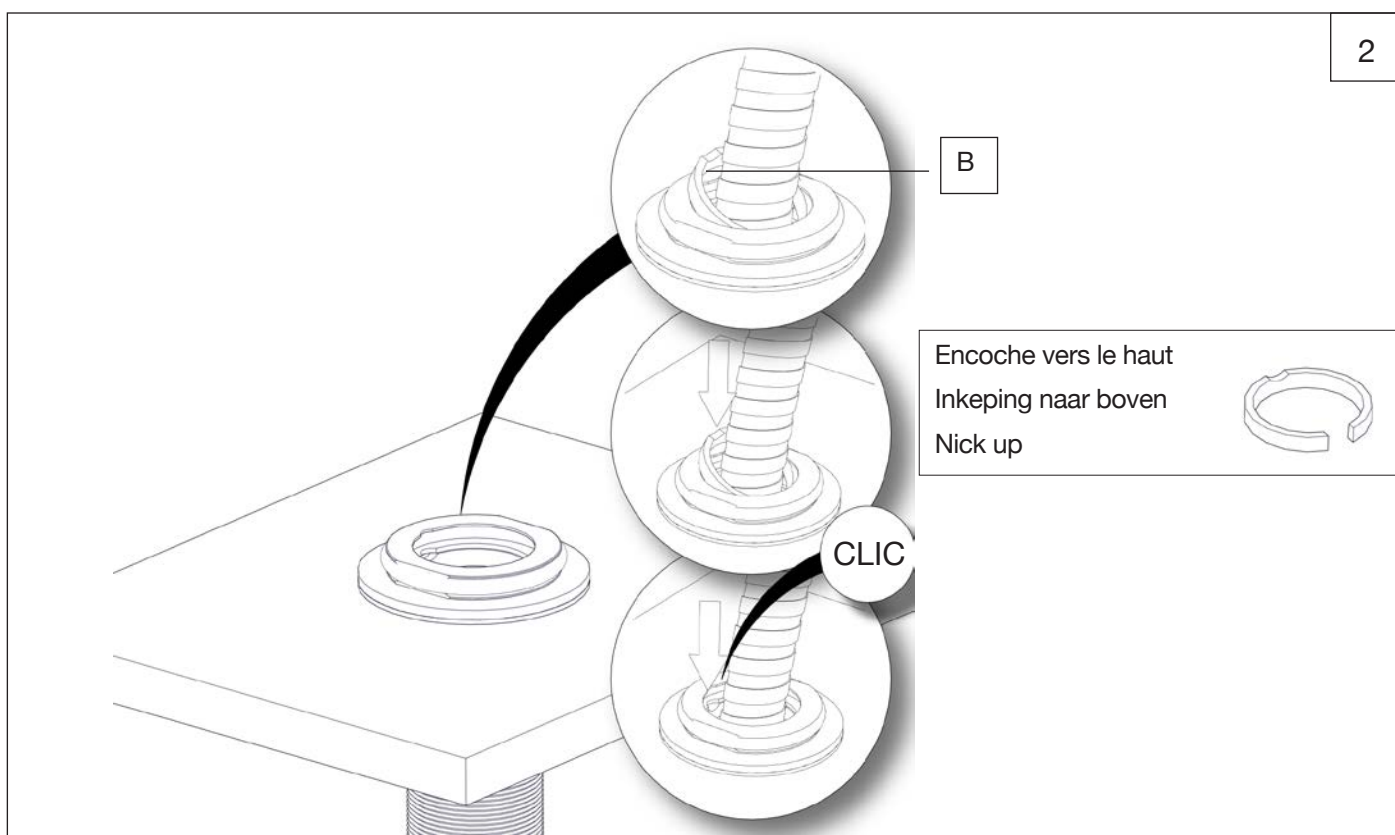
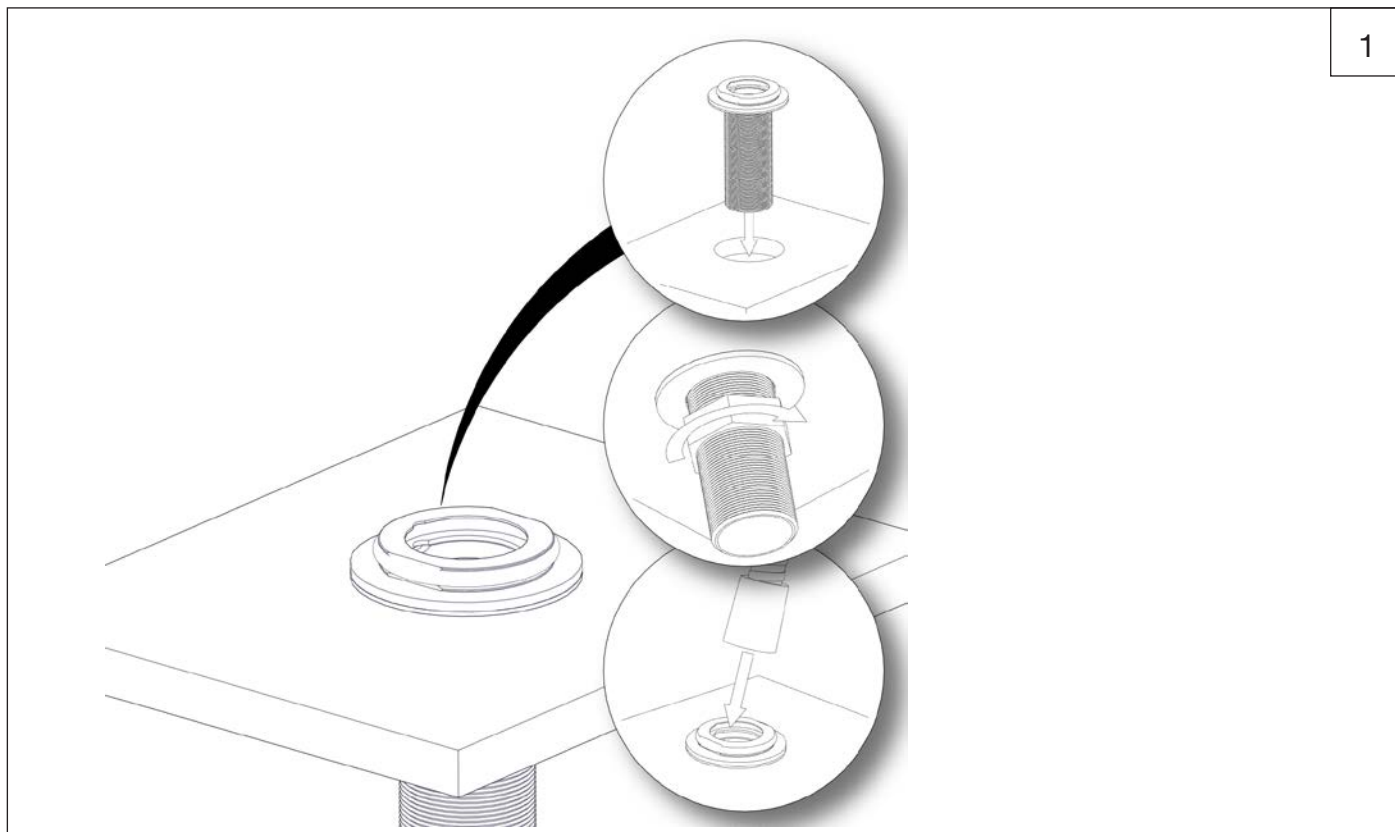

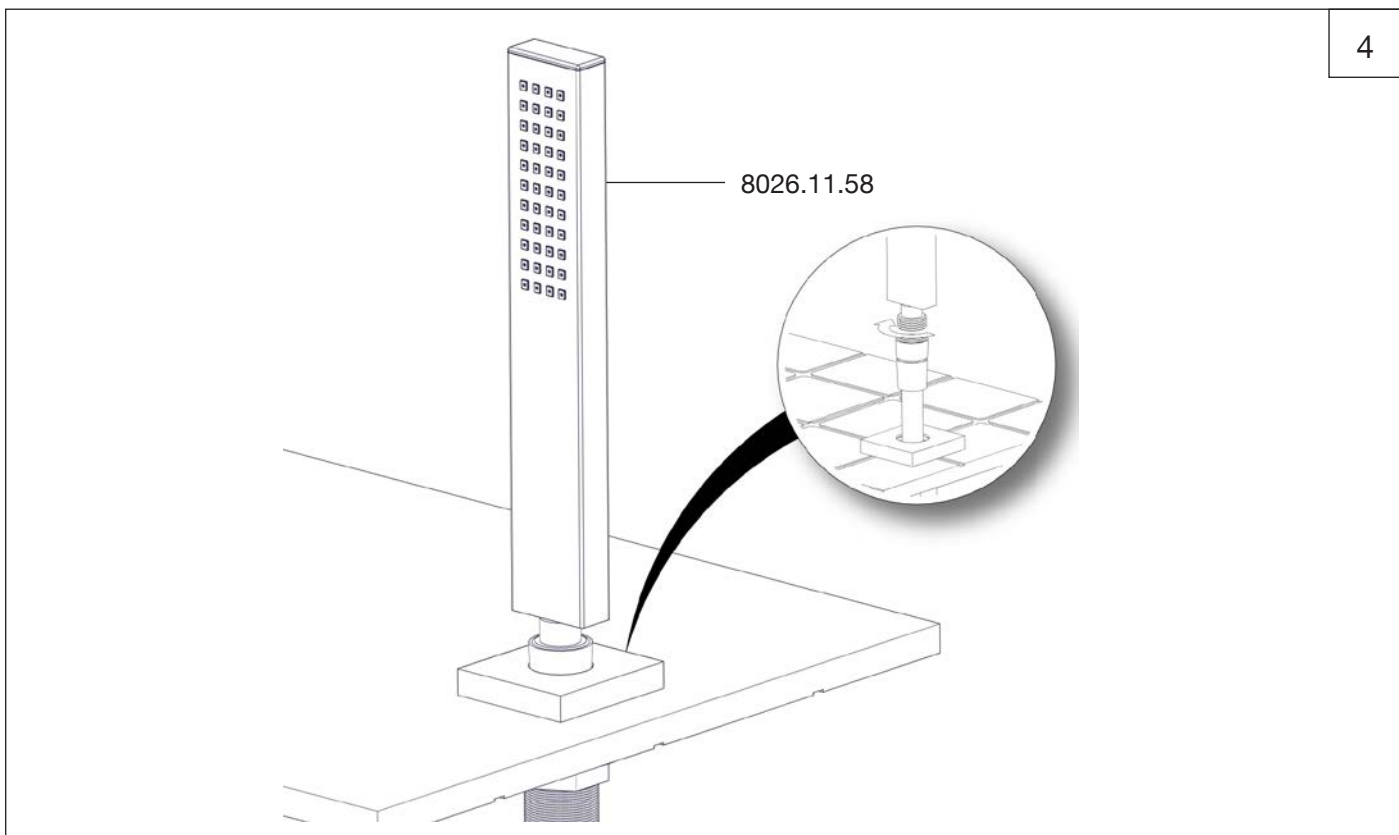
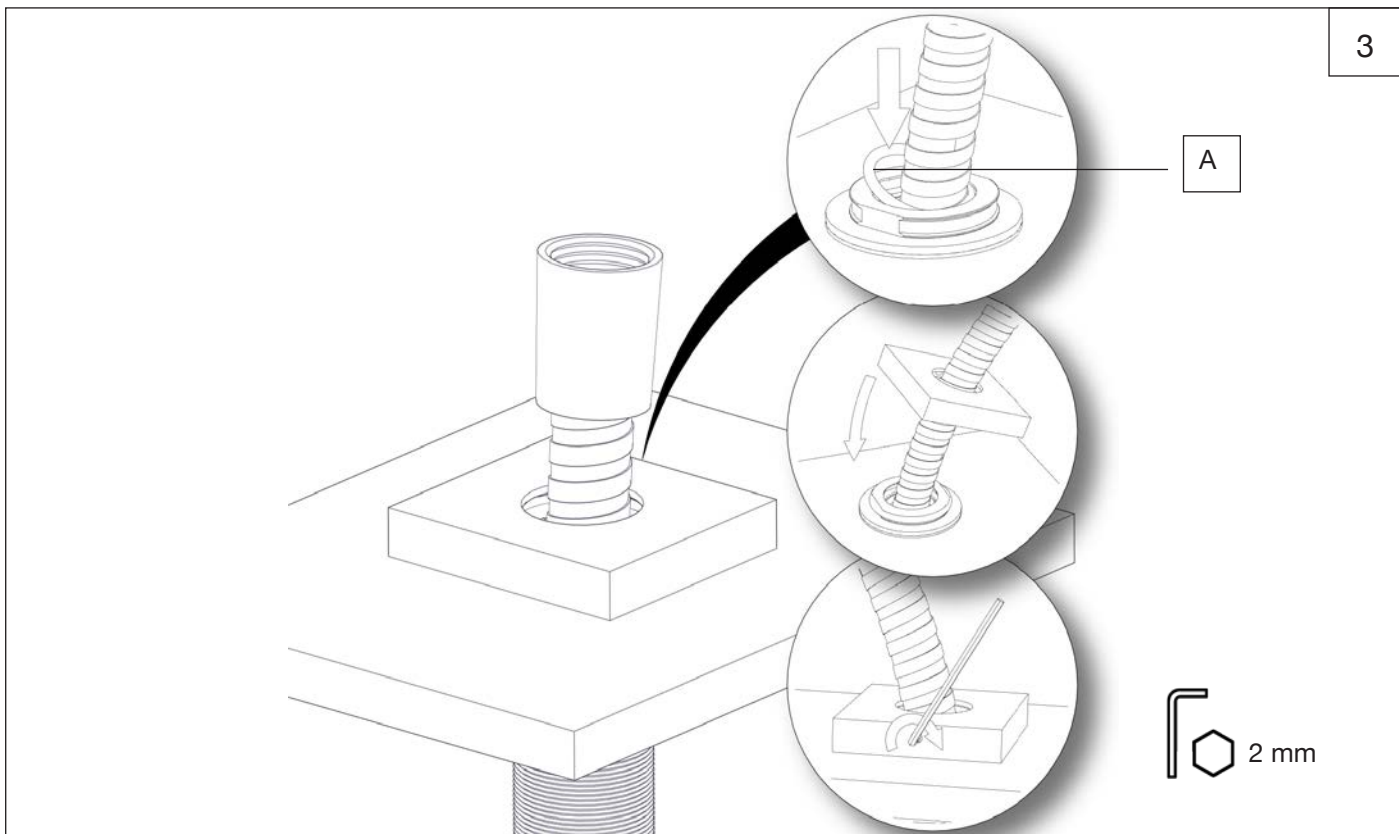

Démontage du flexible si nécessaire
Uit elkaar halen van de slang indien nodig
Disassembly of the flexible if necessary

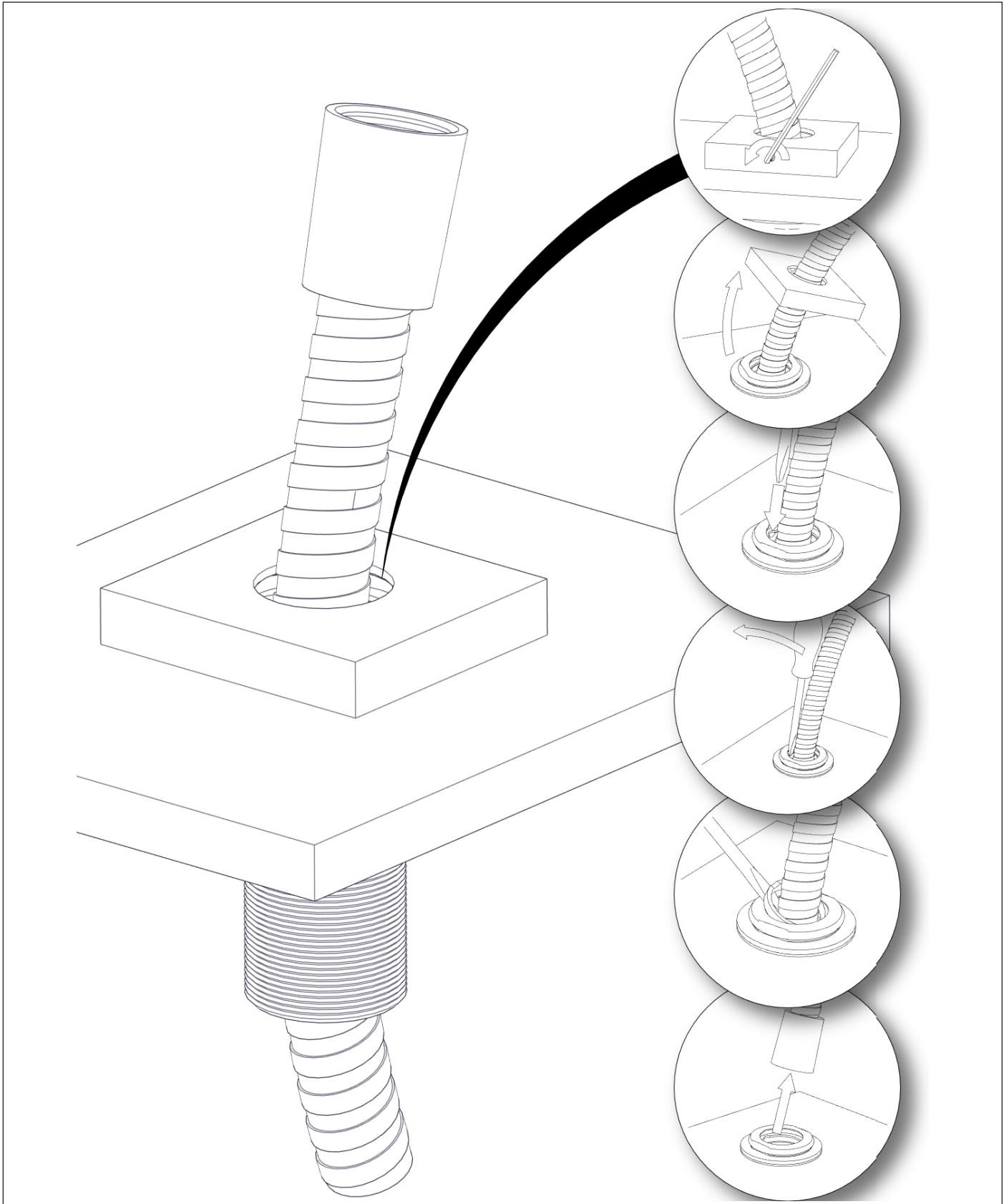



Innovation since 1935

Garantie Garantie Guarantee

F Votre titre de garantie repris sur la présente notice de montage ainsi que votre facture d'achat sont nécessaires pour revendiquer l'application de la garantie.

Conservez-les soigneusement. Voyez les conditions de garantie dans le folder «Entretien et Garantie des produits».

NL Om uw waarborg tot garantie te kunnen opeisen, is het noodzakelijk uw aankoopfactuur samen met uw garantiebewijs zorgvuldig te bewaren. Zie de garantie-voorwaarden in de folder «Onderhoud en waarborg van de producten».

GB Your guarantee voucher as your purchase invoice are necessary to claim the application of the guarantee. Preserve them carefully. You can find the guarantee conditions in the folder «Product Care and Guarantee».

8029.--.58	
------------	--